

TOLERANCES acc. to ISO / TOLERANSEER ent. ISO  
 Applicable where no tolerance is indicated.  
 Gatter der Toleranz ei direkt utsatts  
 For machining / For bearbejning ISO 2768-mk  
 For welding / For svejning SS-EN ISO 13920-BF  
 Surface finish acc. to ISO 15022 Machine surfaces  
 Yjajamhet enligt ISO 1302. For bearbetade ytor.

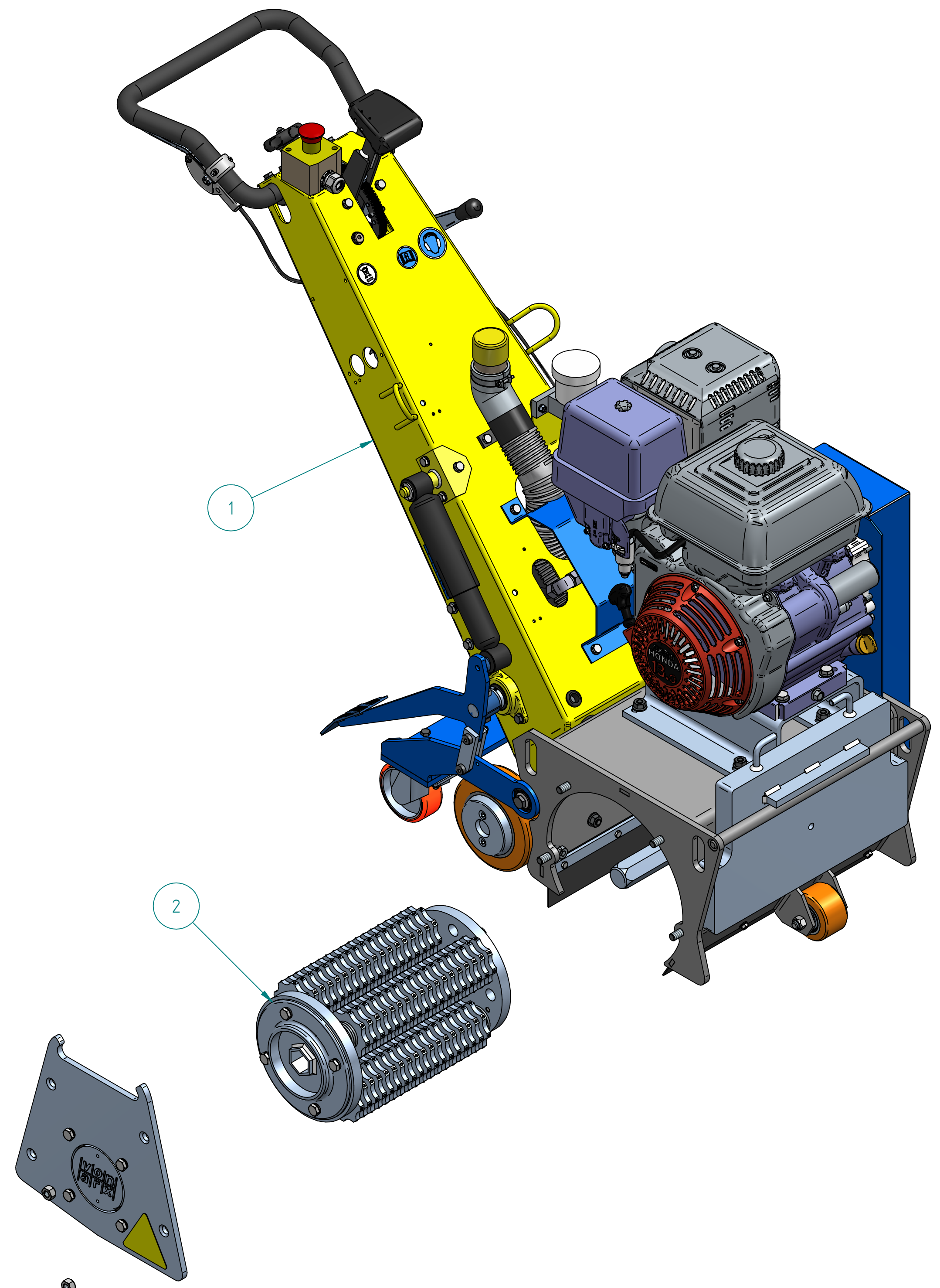

Item	Artikelnummer	Document Number	Title	Quantity
1	707554	668.28.00b	VA 30 SH WITH GASOLINE ENGINE	1
2	701691	630.03.12	DRUM WITH OCTAGONAL CUTTERS FO	1
3	799799		EU - ATTENTION OF CONFORMITY	1
4	799950		OPERATING MANUAL VA 30 SH	1
5	799979		WARRANTY CARD FR	1
6	799954		BROCHURE: QUALITY PRODUCTS	1
7	700603		TUBE MOLYKOTE BR2 PLUS	0.005
8	900001		NAYLON BAG WITH TIE 300 X 470mm	1
9	900063		PALLET 140/80	1
10	900039		CARTON BOX FOR PALLET 139x79x120h	1

THE INFORMATION CONTAINED IN THIS DRAWING IS THE SOLE PROPERTY OF  
 VON ARX. EOOD. REPRODUCTION IN PART OR WHOLE WITHOUT  
 THE WRITTEN PERMISSION OF VON ARX. EOOD. IS PROHIBITED.

Material		Dimension	
Units : mm	SIZE A2		
Drawn By GS	Date 4.9.2019	Approved Date 03.12.2019	Approved By MS
		Description	Article Number
		VA 30 SH WITH GASOLINE ENGINE	707533
Part/Assembly File		sheet of	Rev.
6682812.asm		1 1	