

TOLERANCES acc. to ISO / TOLERANSEER entl. ISO  
 Applicable where no tolerance is indicated.  
 Gatter der Toleranz ei direkt anzeigt  
 For machining / For bearbejning ISO 2768-mk  
 For welding / For svejning ISO 5817  
 Surface finish acc. to ISO 1302  
 Yjajmehet enligt ISO 1302. For bearbetade ytor.

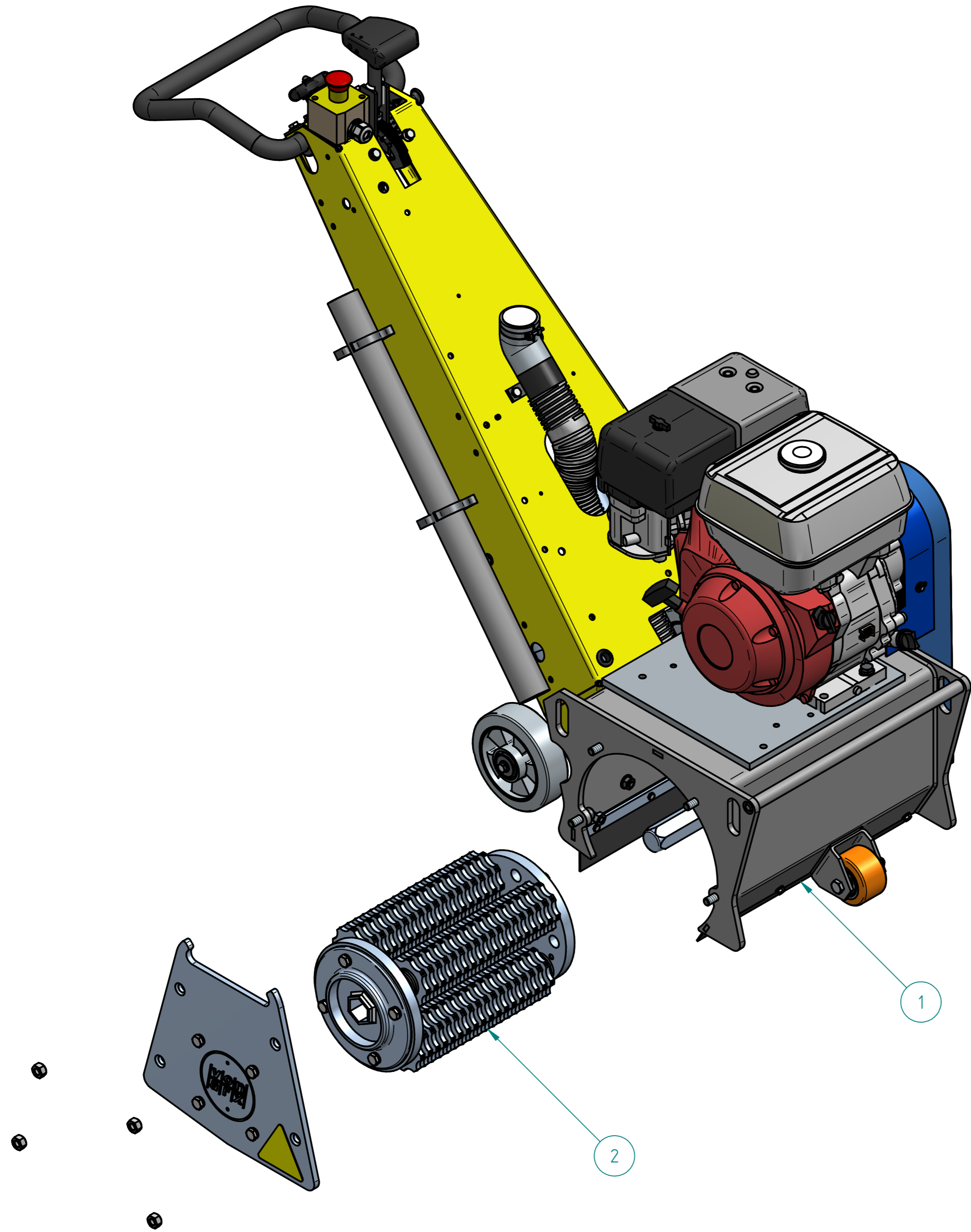

Item	Artikelnummer	Document Number	Title	Quantity
1	703046	665.23.00e	VA-30 S WITH GASOLINE ENGINE	1
2	701691	630.03.12	DRUM WITH OCTAGONAL CUTTERS FO	1
3	799799		EU - ATTENTION OF CONFORMITY	1
4	799954		BROCHURE: QUALITY PRODUCTS	1
5	799970		BA FR/VA PART A	1
6	799979		WARRANTY CARD FR	1
7	700603		TUBE MOLYKOTE BR2 PLUS	0.005
8	900001		NAYLON BAG WITH TIE 300 X 470mm	1
9	900063		EURO PALLET 140/80	1
10	900039		CARTON BOX FOR PALLET 139x79x120h	1

THE INFORMATION CONTAINED IN THIS DRAWING IS THE SOLE PROPERTY OF VON ARX. EXACT REPRODUCTION IN PART OR WHOLE WITHOUT THE WRITTEN PERMISSION OF VON ARX. EXACT IS PROHIBITED.

Material		Dimension	
Units : mm	SIZE A2		
Drawn By GS	Date 16.5.2019	Approved Date 21.02.2020	Approved By MS
		Description VA 30S W. GASOLINE ENGINE HOND	Article Number 706275
		DWG NO 665.23.12	
Part/Assembly File 6652312.asm		sheet 1	of 1
			Rev.