

TOLERANCES acc. to ISO / TOLERANSEER entl. ISO  
 Applicable where no tolerance is indicated.  
 Gtler der Toleranz ei direkt utsatts  
 For machining / For bearbejning ISO 2768-mk  
 For welding / For svejtnng SS-EN ISO 13920-BF  
 Surface finish acc. to ISO 1502 Machine surfaces  
 Yjajmetel entlgt ISO 1302 For bearbejtede ytor

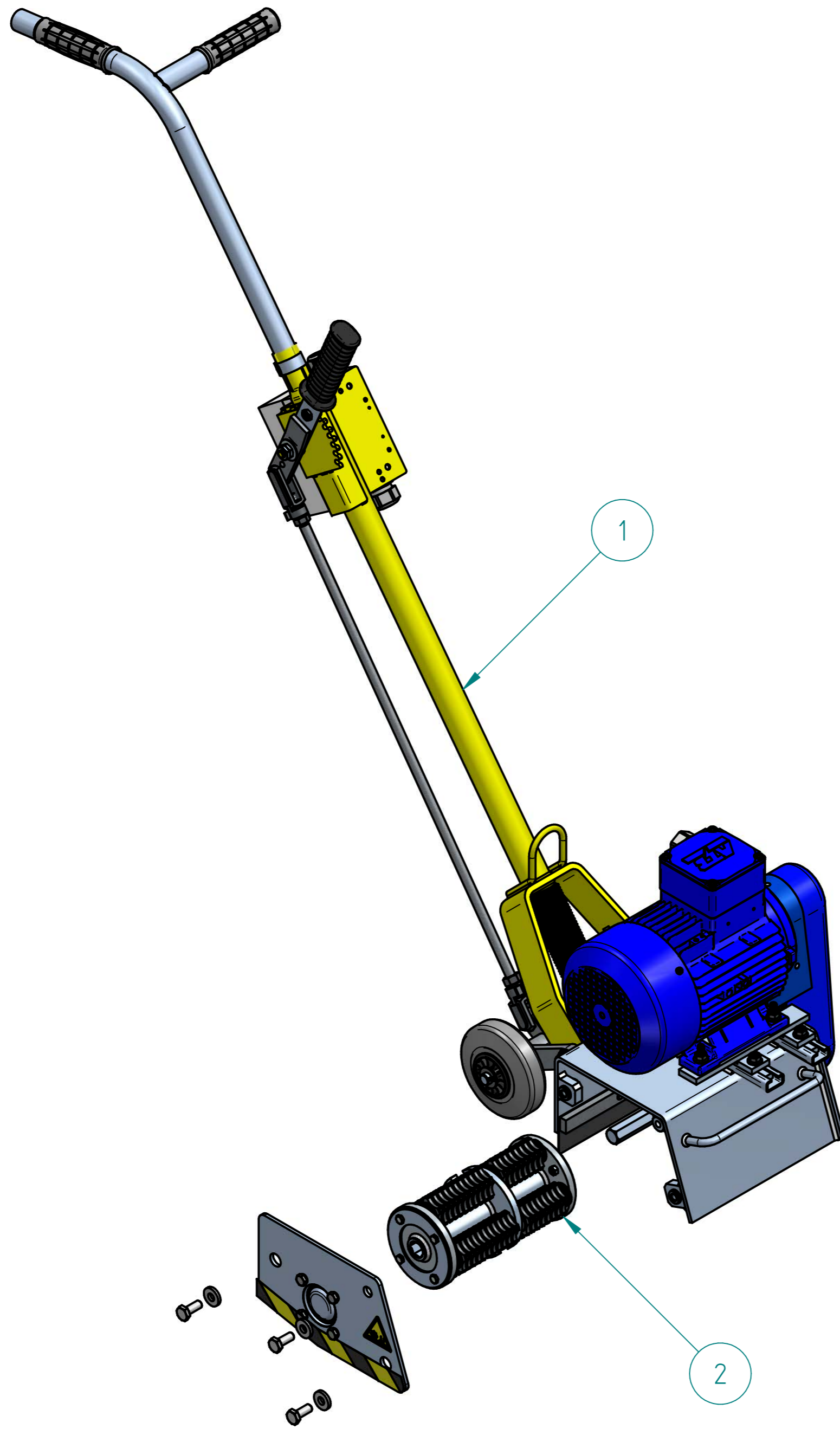

Item	Artikelnummer	Document Number	Title	Quantity
1	800005	625.62.00	FR 200 WITH ELMOTOR 115 V	1
2	701422	625.11.13	DRUM WITH PENTAGONAL CUTTERS F	1
3	706309		FOLDING BOX BOARD FR 200	1
4	706310		CUTTING PLYWOOD 9MM	1
5	706311		INSERT WITH HOLE FOR BOXES FR	1
6	708796		CUT OF FLAKE BOARD	1
7	799799		EU - ATTENTION OF CONFORMITY	1
8	799972		OPERATING MANUAL FR200	1
9	799979		WARRANTY CARD FR	1
10	900001		NAYLON BAG WITH TIE 300 X 470mm	1
11	103022	792.65.09	ALLEN KEY	1
12	108042	792.65.01	FORK WRENCH	1
13	109332		CABLE STRAPS	2
14	700603		TUBE MOLYKOTE BR2 PLUS	0,1
15	900017		ZIPPED NAYLON BAG 13 x 16 cm	1
16	799954		BROCHURE QUALITY PRODUCTS	1

THE INFORMATION CONTAINED IN THIS DRAWING IS THE SOLE PROPERTY OF  
 VON ARX. EOOD REPRODUCTION IN PART OR WHOLE WITHOUT  
 THE WRITTEN PERMISSION OF VON ARX EOOD IS PROHIBITED

Material		Dimension	
Drawn By MS	Date 11-Feb-20	Approved Date 11.02.2020	Approved By MS
Units : mm		SIZE A2	
		Description FR 200 1.1kW 115V / 60Hz	Article Number 800006
		DWG NO 625.62.13	
Part/Assembly File 6256213.asm		sheet 1	of 1
			Rev.